



Level



Pressure



Flow



Temperature



Liquid
Analysis



Registration



Systems
Components



Services



Solutions

Technical Information

Orbisint CPS11 and CPS11D

pH electrodes, analogue and digital with Memosens technology

For standard applications in process and environment technology, with dirt-repellent PTFE diaphragm, optional built-in temperature sensor



Application

- Long-term monitoring and limit monitoring of processes with stable process conditions
 - Paper industry
 - Plastics chemistry
 - Power plants (e.g. flue gas washers)
 - Incineration plants
 - Food industry
 - Breweries
- Water treatment
 - Drinking water
 - Cooling water
 - Well water



With ATEX and FM approval for application in hazardous areas

Your benefits

- Robust electrode requiring low maintenance due to large PTFE ring diaphragm
- Certified biocompatibility
- Application under pressures of up to 6 bar / 87 psi
- Long service life due to double junction system of metal lead and thus long electrode poison diffusion path
- Sterilisable
- Process glass for highly alkaline applications available
- With optional built-in Pt 100 or Pt 1000 temperature sensor for effective temperature compensation
- Rugged TOP 68 plug-in system for reliable measured value transfer

Further benefits offered by Memosens technology

- Maximum process safety through contactless inductive signal transmission
- Data safety through digital data transmission
- Easy handling due to storage of sensor-specific data
- Predictive maintenance possible due to registration of sensor load data

Function and system design

Measuring principle

pH measurement

The pH value is used as a unit of measurement for the acidity or alkalinity of a liquid medium. The membrane glass of the electrode supplies an electrochemical potential which is dependent upon the pH value of the medium. This potential is generated by the selective penetration of H⁺ ions through the outer layer of the membrane. An electrochemical boundary layer with an electric potential forms at this point. An integrated Ag/AgCl reference system serves as reference electrode.

The transmitter converts the measured voltage into the corresponding pH value using the Nernst equation.

General properties

■ Low maintenance

The sterilisable dirt-repellent PTFE ring diaphragm of the electrode prevents blocking and assures long-time stability and accuracy.

■ Long service life

The double junction system of the metal lead offers better protection from electrode poisons and guarantees a considerably longer service life.

■ Durability

Depending on the ordered version, the electrode is pressure proof up to 6 bar / 87 psi and can be applied with temperatures of up to 135 °C / 275 °F.

Important properties of CPS11D

Maximum process safety

The inductive and non-contacting measured value transfer of Memosens guarantees maximum process safety and offers the following benefits:

- All problems caused by moisture are eliminated.
 - The plug-in connection is free from corrosion.
 - Measured value distortion from moisture is not possible.
 - The plug-in system can even be connected under water.
- The transmitter is galvanically decoupled from the medium. The result: No more need to ask about "symmetrically high-impedance" or "unsymmetrical" or an impedance converter.
- The cable does not act like an antenna. Thus, EMC safety is guaranteed.

Data safety through digital data transfer

The Memosens technology digitalises the measured value in the sensor and transfers it to the transmitter via a contactless connection. The result:

- An automatic error message is generated if the sensor fails or the connection between sensor and transmitter is interrupted
- The availability of the measuring point is dramatically increased by immediate error detection
- The digital signals are suitable for application in hazardous areas; the integrated electronics are intrinsically safe.

Easy handling

Sensors with Memosens technology have integrated electronics that allow for saving calibration data and further information such as total hours of operation and operating hours at very low or very high pH values. When the sensor is mounted, the calibration data are automatically transferred to the transmitter and used to calculate the current pH value: Storing the calibration data in the sensor allows for calibration and adjustment away from the measuring point. The result:

- pH sensors can be calibrated under optimum external conditions in the measuring lab. Wind and weather do neither affect the calibration quality nor the operator.
- The measuring point availability is dramatically increased by the quick and easy replacement of precalibrated sensors.
- The transmitter does not need to be installed close to the measuring point but can be placed in the control room.
- Maintenance intervals can be defined based on all stored sensor load data and calibration and predictive maintenance is possible.
- The sensor history can be documented on external data carriers and evaluation programs at any time. Thus, the current application of the sensors can be made to depend on their previous history.

Communication with the transmitter

Always connect the CPS11D to a transmitter with Memosens technology. Data transmission to a standard transmitter is not possible.

Data storage of CPS11D

Digital sensors are able to store the following system data in the sensor.

- Manufacturing data
 - Serial number
 - Order code
 - Date of manufacture
- Calibration data
 - Calibration date
 - Calibrated slope at 25 °C / 77 °F
 - Calibrated zero point at 25 °C / 77 °F
 - Temperature offset
 - Number of calibrations
 - Operator's signature for calibration or adjustment
- Application data
 - Temperature application range
 - pH application range
 - Date of first commissioning
 - Maximum temperature value
 - Operating hours at temperatures above 80 °C / 176 °F and 100 °C / 212 °F
 - Operating hours at very low and very high pH values (Nernst voltage below -300 mV, above +300 mV)
 - Number of sterilisations
 - Glass membrane impedance

These system data can be displayed with the Mycom S transmitter

Measuring system

A complete measuring system comprises:

- CPS11 pH electrode or CPS11D digital sensor
- Transmitter, e.g. Liquisys M CPM223/253 (with Memosens technology for CPS11D)
- Special measuring cable, e.g. CPK9 or Memosens data cable CYK10
- Immersion, flow or retractable assembly, e.g. Cleanfit P CPA472

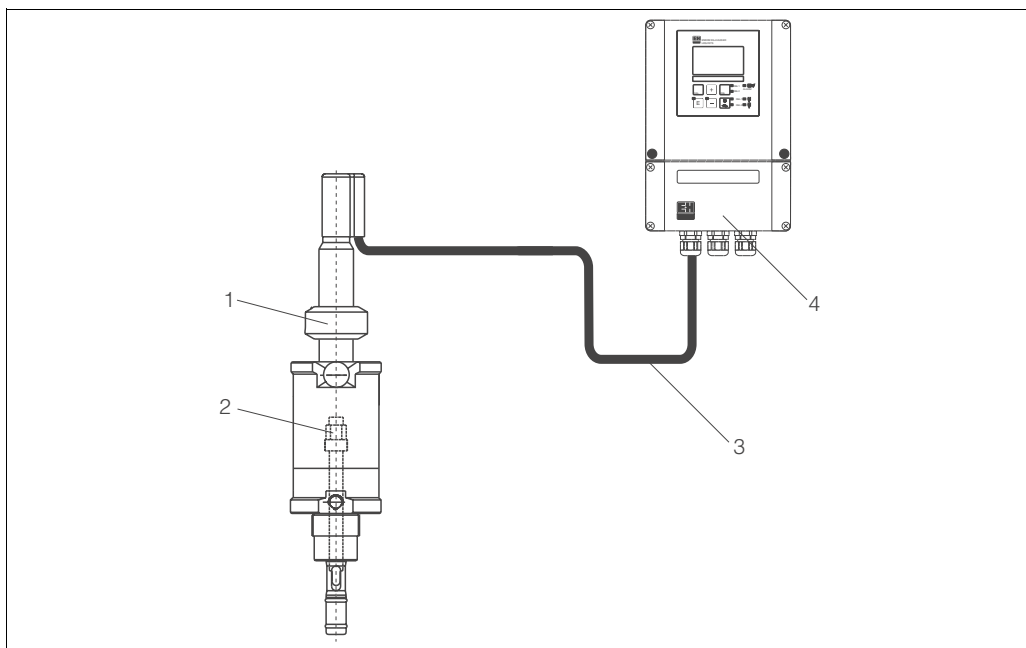

C07-CPS11Dx-14-05-00-xx-001.eps

Measuring system for pH measurement

- 1 Cleanfit P CPA472 retractable assembly
- 2 CPS11 pH electrode
- 3 Special measuring cable CPK9 (for electrodes with TOP68 plug-in head) / CYK10 for digital sensors
- 4 Liquisys M CPM253 transmitter

Input

Measured variables

pH value
Temperature

Measuring range

Electrode version AA (for water / wastewater):
 pH: 0 ... 12 pH
 Temperature: -15 ... 80 °C / 5 ... 176 °F
 Electrode version BA (for process applications, sterilisable)
 pH: 0 ... 14 pH
 Temperature: 0 ... 135 °C / 32 ... 275 °F
 Electrode version FA (for hydrofluoric acid):
 pH: 0 ... 10 pH
 Temperature: 0 ... 70 °C / 32 ... 158 °F



Caution!
Please note the process operating conditions.

Installation

Installation instructions

Do not install the electrode upside down. The inclination angle must be at least 15° from the horizontal. A smaller inclination angle is not permitted as such an inclination results in air cushion forming in the glass sphere. This might impair full wetting of the pH membrane with inner electrolyte.



Caution!

- Make sure that the assembly's threaded connection for the electrode is clean and well running before installing the electrode.
- Hand tighten the electrode (3 Nm)! (Given value only applies to installation Endress+Hauser assemblies.)
- Make sure to follow the installation instructions in the operating instructions of the used assembly.

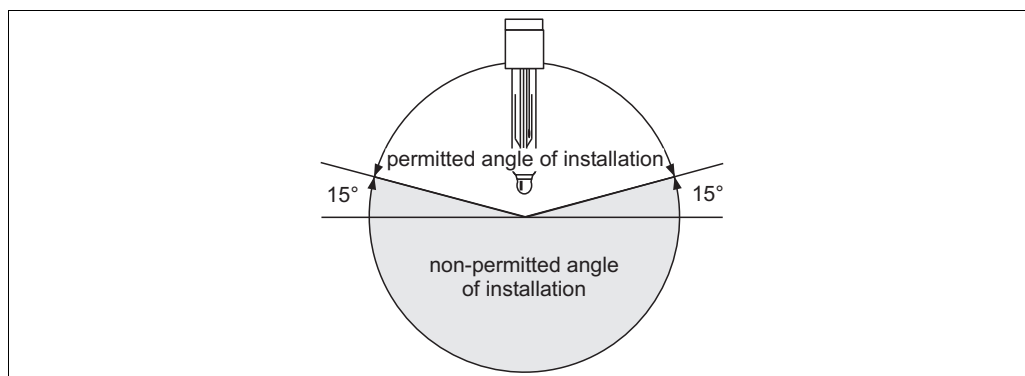

Electrode installation; installation angle min. 15° from the horizontal

C07-CPS71xxx-03-05-00-en-001.eps

Environment

Ambient temperature



Caution!
Danger of frost damage
Do not use the electrode at temperatures below -15 °C / 5 °F.

Storage temperature

0 ... 50 °C / 32 ... 122 °F

Ingress protection

IP 67: GSA plug-in head (with closed plug-in connection)
 IP 68: TOP 68 plug-in head, autoclavable up to 135 °C / 275 °F (1 m / 3.28 ft water column, 50 °C / 122 °F, 168 h)
 IP 68: Memosens plug-in head (10 m/ 32.81 ft water column, 25 °C / 77 °F, 45 days, 1M KCl)

Process

Process temperature

Version AA: -15 ... 80 °C / 5 ... 176 °F
 Version BA: 0 ... 135 °C / 32 ... 275 °F
 Version FA: 0 ... 70 °F / 32 ... 158 °F

Process pressure

0 ... 6 bar / 0 ... 87 psi

Pressure temperature load curve

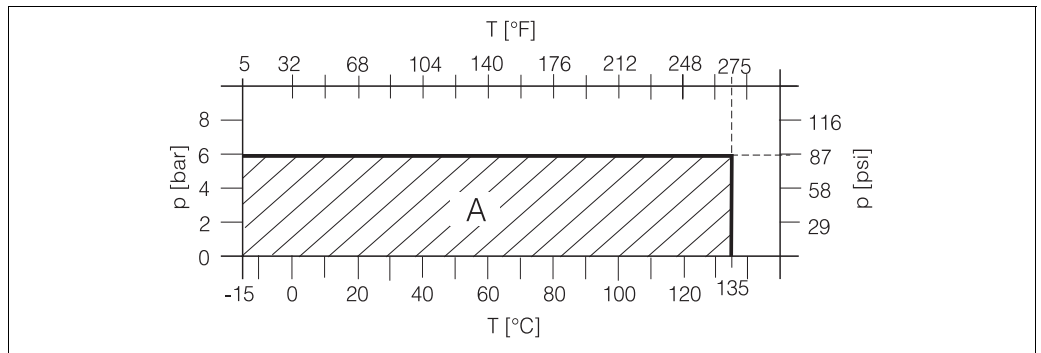

C07-CPS11xxxx-05-05-00-en-001.eps

Conductivity

min. 50 µS/cm

pH range

Version AA: 0 ... 12 pH
 Version BA: 0 ... 14 pH
 Version FA: 0 ... 10 pH



Caution!
Danger of electrode damage
 Do not operate the electrodes in applications outside the given specifications!

Mechanical construction

Design, dimensions

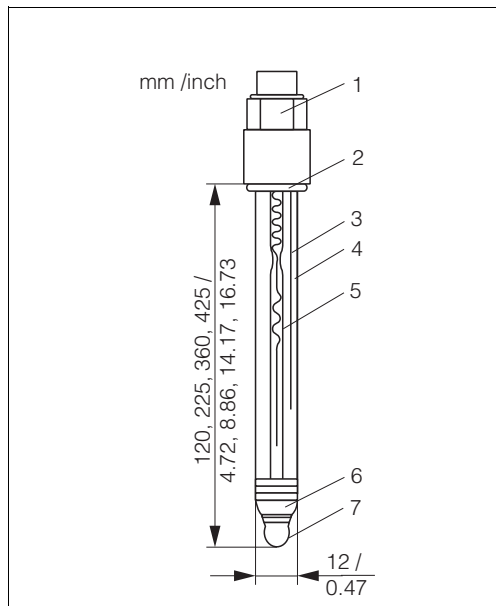

CPS11 with GSA plug-in head

- 1 GSA plug-in head, Pg 13.5
- 2 EPDM O-ring with thrust collar
- 3 Ag/AgCl metal lead
- 4 "Advanced Gel" electrolyte
- 5 Ag/AgCl metal lead
- 6 PTFE diaphragm
- 7 pH glass membrane

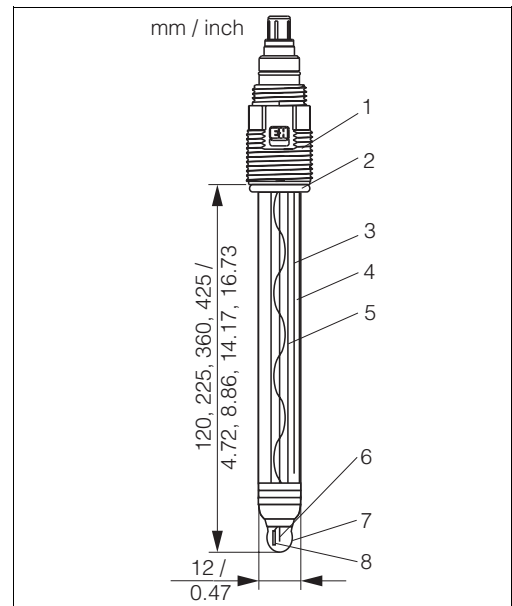

CPS11 with ESA plug-in head, temperature sensor

- 1 TOP68 plug-in head, Pg 13.5
- 2 EPDM O-ring with thrust collar
- 3 Ag/AgCl metal lead
- 4 "Advanced Gel" electrolyte
- 5 Ag/AgCl metal lead
- 6 PTFE diaphragm
- 7 pH glass membrane
- 8 Pt 100 temperature sensor

Design, dimensions CPS11D

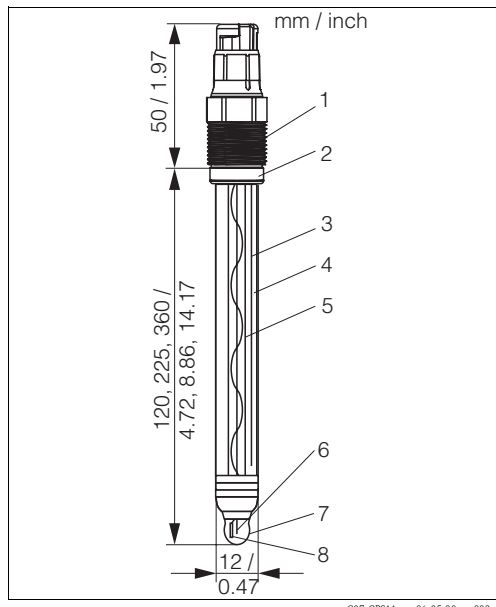

CPS11D with Memosens plug-in head, temperature sensor

- 1 Memosens plug-in head, Pg 13.5
- 2 Viton O-ring, Viton thrust collar
- 3 Ag/AgCl metal lead
- 4 "Advanced Gel" electrolyte
- 5 Ag/AgCl metal lead
- 6 PTFE diaphragm
- 7 pH glass membrane
- 8 Temperature sensor

Weight	approx. 0.1 kg / 0.2 lb.	
Material	Electrode shaft pH membrane glasses Metal lead Diaphragm	process glass types A, B, F Ag/AgCl ring-shaped Teflon® diaphragm, sterilisable
Process connection	Pg 13.5	
Temperature sensor	CPS11: CPS11D:	Pt 100, Pt 1000 NTC
Plug-in heads	CPS11: ESA: GSA: CPS11D:	plug-in head Pg 13.5, TOP68 for electrodes with or without temperature sensor, 16 bar / 232 psi triple overpressure safety, Ex plug-in head Pg 13.5 for electrodes without temperature sensor Memosens plug-in head for digital, contactless data transmission
Reference system	Ag/AgCl metal lead with Advanced Gel 3 molar KCl, AgCl free	

Certificates and approvals

Ex approval CPS 11 (ESA) and CPS11D	<ul style="list-style-type: none"> ■ ATEX II 1G EEX ia IIC T3/T4/T6 ■ FM Class I Div. 2, in combination with the Mypro CPM431 and Mycom S CPM153 transmitters (CPS11 only)
Biocompatibility	Biocompatibility validated according to: <ul style="list-style-type: none"> ■ ISO 10993-5:1993 ■ USP, current revision
TÜV certificate TOP68 plug-in head	Pressure resistance 16 bar, min. triple overpressure safety
Electromagnetic compatibility of CPS11D	Interference emission and interference immunity complies with EN 61326: 1997 / A1: 1998

Ordering information

Product structure CPS11

		Electrode type	
	1	without temperature sensor	
	2	with built-in Pt 100 (not available with GSA plug-in head)	
	3	with built-in Pt 1000 (not available with GSA plug-in head)	
		Application range	
	AA	pH = 0 ... 12, T = -15 ... 80 °C / 5 ... 176 °F, 6 bar / 87 psi	
	BA	pH = 0 ... 14, T = 0 ... 135 °C / 32 ... 275 °F, sterilisable, 6 bar / 87 psi	
	FA	pH = 0 ... 10, T = 0 ... 70 °C / 32 ... 158 °F, HF resistant up to 1 g/l, 6 bar / 87 psi	
		Shaft length	
	2	120 mm / 4.72"	
	4	225 mm / 8.86"	
	5	360 mm / 14.17"	
	6	425 mm / 16.73"	
		Plug-in head	
	ESA	Plug-in head Pg 13.5, TOP 68, 16 bar / 232 psi, Ex	
	GSA	Plug-in head Pg 13.5, DIN coax, non-Ex	
CPS11-			complete order code

Product structure CPS11D

		Version	
	7	max. 135 °C / 275 °F, built-in temperature sensor	
		Application range	
	AA	pH = 0 ... 12, T = -15 ... 80 °C / 5 ... 176 °F, 6 bar / 87 psi	
	BA	pH = 0 ... 14, T = 0 ... 135 °C / 32 ... 275 °F, sterilisable, 6 bar / 87 psi	
	FA	pH = 0 ... 10, T = 0 ... 70 °C / 32 ... 158 °F, HF resistant up to 1 g/l, 6 bar / 87 psi	
		Shaft length	
	2	120 mm / 4.72"	
	4	225 mm / 8.86"	
	5	360 mm / 14.17"	
	6	425 mm / 16.73"	
		Options	
	1	Standard	
CPS11D-			complete order code

Accessories

Assemblies (selection)

- Cleanfit W CPA450
Manually operated, retractable assembly for pH/redox electrodes, for installation of 120 mm / 4.72" electrodes in tanks and pipes,
Ordering acc. to product structure, see Technical Information (TI 183C/07/en, order no. 50090677)
(Make sure to order the correct inner tube for your electrode version.)
- Cleanfit P CPA471
Compact retractable stainless steel assembly for installation in tanks and pipes, manual or pneumatic operation
Ordering acc. to product structure, see Technical Information (TI 217C/07/en, order no. 51502596)
- Cleanfit P CPA472
Compact retractable plastic assembly for installation in tanks and pipes, manual or pneumatic operation,
Ordering acc. to product structure, see Technical Information (TI 223C/07/en, order no. 51502645)
- Cleanfit P CPA473
Retractable stainless steel process assembly, with ball valve for a particularly safe and reliable separation of the medium from the environment,
Ordering acc. to product structure, see Technical Information (TI 344C/07/en, order no. 51510923)
- Cleanfit P CPA474
Retractable plastic process assembly, with ball valve for a particularly safe and reliable separation of the medium from the environment,
Ordering acc. to product structure, see Technical Information (TI 345C/07/en, order no. 51510925)

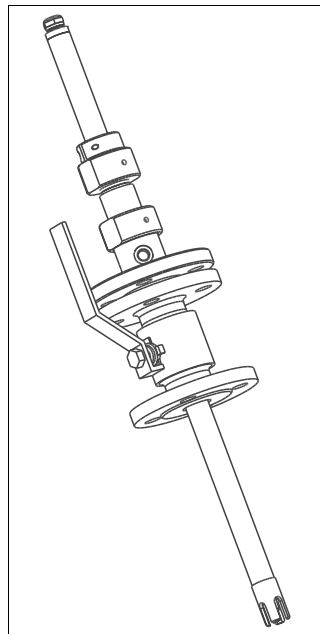

C07-CPA450xx-21-07-06-xx-001.eps

Cleanfit W CPA450

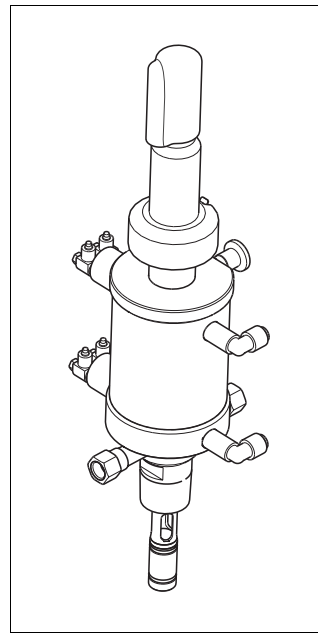

C07-CPA471ZY-21-07-06-xx-001.eps

Cleanfit P CPA471 or 472

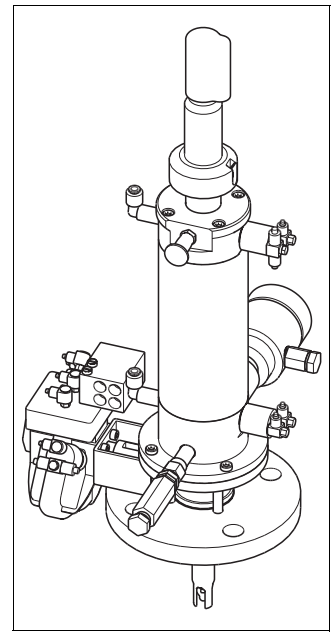

C07-CPA473xx-21-07-06-xx-002.eps

Cleanfit P CPA473 or 474

- Cleanfit H CPA475
 Retractable assembly for installation in tanks and pipes under sterile conditions,
 Ordering acc. to product structure, see Technical Information (TI 240C/07/en, order no. 51505599)
- Unifit H CPA442
 Process assembly for the food industry, biotechnology and pharmaceutical industry, with EHEDG and 3A certificates,
 Ordering acc. to product structure, see Technical Information (TI 306C/07/en, order no. 51507254)
- Dipfit W CPA111
 Plastic immersion and installation assembly for open and closed tanks,
 Ordering acc. to product structure, see Technical Information (TI 112C/07/en, order no. 50066450)

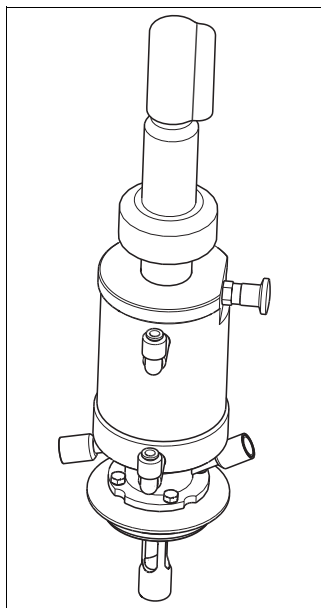

C07-CPA475FY-21-07-06-xx-001.eps

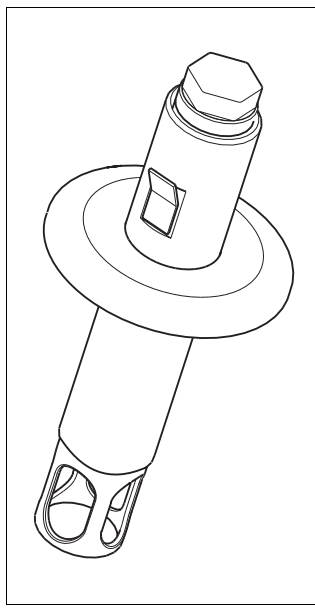
Cleanfit H CPA475

C07-CPA442FY-21-07-06-xx-001.eps

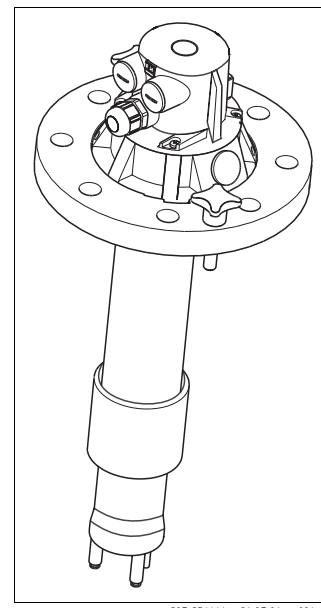
Unifit H CPA442

C07-CPA111xx-21-07-06-xx-001.eps

Dipfit W CPA111

- Dipfit P CPA140
 Immersion assembly for pH/redox electrodes for demanding processes,
 Ordering acc. to product structure, see Technical Information (TI 178C/07/en, order no. 50088968)
- Flowfit P CPA240
 Flow assembly for pH/redox electrodes, for demanding processes,
 Ordering acc. to product structure, see Technical Information (TI 179C/07/en, order no. 50088970)
- Flowfit W CPA250
 Flow assembly for pH/redox measurement,
 Ordering acc. to product structure, see Technical Information (TI 041C/07/en, order no. 50036058)

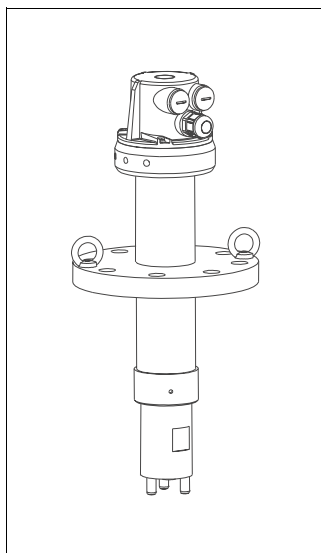

C07-CPA140xx-21-07-00-xx-001.eps

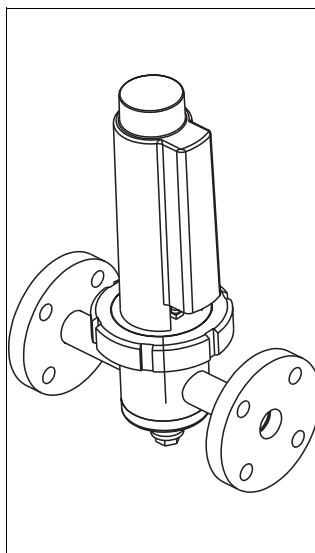
Dipfit P CPA140

C07-CPA240xx-21-07-06-xx-001.eps

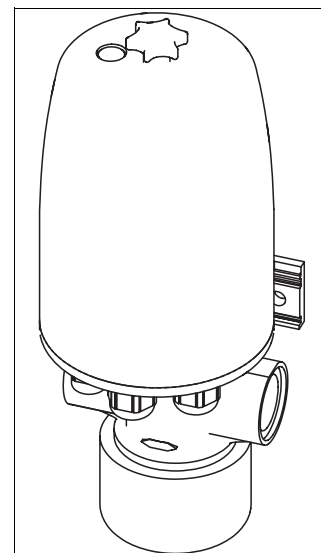
Flowfit P CPA240

C07-CPA250xx-21-07-06-xx-002.eps

Flowfit W CPA250

- Probit H CPA465
Retractable assembly for installation in tanks and pipes under sterile conditions,
Ordering acc. to product structure, see Technical Information (TI 146C/07/en, order no. 50076878)
- Ecofit CPA640
Process connection adapter and cable set for 120 mm pH electrodes with TOP68 plug-in head,
Ordering acc. to product structure, see Technical Information (TI 264C/07/en, order no. 51506405)

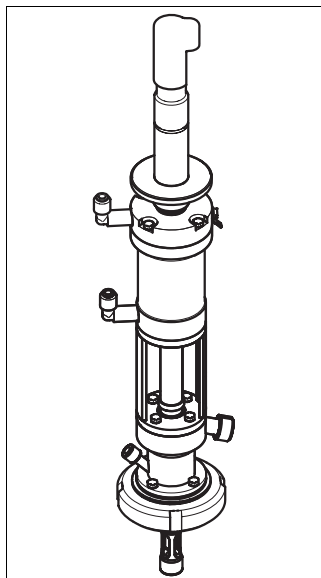

C07-CPA465xx-21-07-06-xx-002.eps

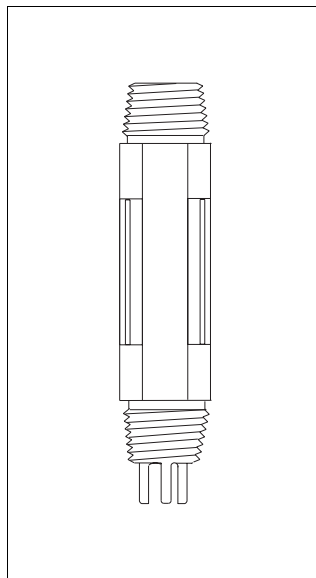
Probit H CPA465

C07-CPA640xx-21-07-00-xx-001.eps

Ecofit CPA640

Buffer solutions

Technical buffer solutions, accuracy 0.02 pH, acc. to NIST/DIN

- pH 4.0 red, 100 ml (0.026 US gal.), order no. CPY 2-0
- pH 4.0 red, 1000 ml (0.264 US gal.), order no. CPY 2-1
- pH 7.0 green, 100 ml (0.026 US gal.), order no. CPY 2-2
- pH 7.0 green, 1000 ml (0.264 US gal.), order no. CPY 2-3

Technical buffer solutions for single use, accuracy 0.02 pH, acc. to NIST/DIN

- pH 4.0 20 x 20 ml (0.005 US gal.), order no. CPY 2-D
- pH 7.0 20 x 20 ml (0.005 US gal.), order no. CPY 2-E

Measuring cables

- CPK9 special measuring cable
For electrodes with TOP 68 plug-in head, for high-temperature and high-pressure applications, IP 68
Ordering acc. to product structure, see Technical Information (TI 118C/07/en)
- CPK1 special measuring cable
For pH/redox electrodes with GSA plug-in head
Ordering acc. to product structure, see Technical Information (TI 118C/07/en)
- CPK12 special measuring cable
For pH/redox glass electrodes and ISFET sensors with TOP68 plug-in head
Ordering acc. to product structure, see Technical Information (TI 118C/07/en)

- CYK10 Memosens data cable
 For digital pH sensors with Memosens technology (CPSxxD)
 Ordering according to product structure, see below

Certificates	
A	Standard, non Ex
G	ATEX II 1G EEx ia IIC T6/T4
O	FM CLI Div. 1 AEx ia IIC T6/T4
S	CSA IS CLI Ex ia IIC T6/T4
Cable length	
03	Cable length: 3 m / 9.84 ft
05	Cable length: 5 m / 16.41 ft
10	Cable length: 10 m / 32.81 ft
15	Cable length: 15 m / 49.22 ft
20	Cable length: 20 m / 65.62 ft
25	Cable length: 25 m / 82.03 ft
Ready-made	
1	Wire terminals
CYK10-	complete order code

Documentation

Transmitters

- Liquisys M CPM223/253, Technical Information TI 194C/07/en; order no. 51500277
 Mycom S CPM153, Technical Information TI 233C/07/en; order no. 51503788
 Mypro CPM431, Technical Information TI 173C/07/en; order no. 50088309

Measuring cables

- CPK1-12, Technical Information TI 118C/07/en; order no. 50068526

Memosens

- Memosens, Technical Information TI 376C/07/en; order no. 51513172

International Head Quarters

Endress+Hauser
 GmbH+Co. KG
 Instruments International
 Colmarer Str. 6
 79576 Weil am Rhein
 Deutschland

Tel. +49 76 21 9 75 02
 Fax +49 76 21 9 75 34 5
 www.endress.com
 info@ii.endress.com